

## Диагностика автомобилей SIS/CAS

Автомобиль	MAZDA / 626 2.0i 16V Hatchback / 09/1991 - 05/1994 / Седан-накл.з.ч./б.накл.з.части
Страна происхождения	J
Литраж/Мощность	2.0 / 85 - 86 kW
Характеристика двигателя	FS
Ключ RB	MAZ 346
Область	Всего
Система	Управление двигателем / EGI

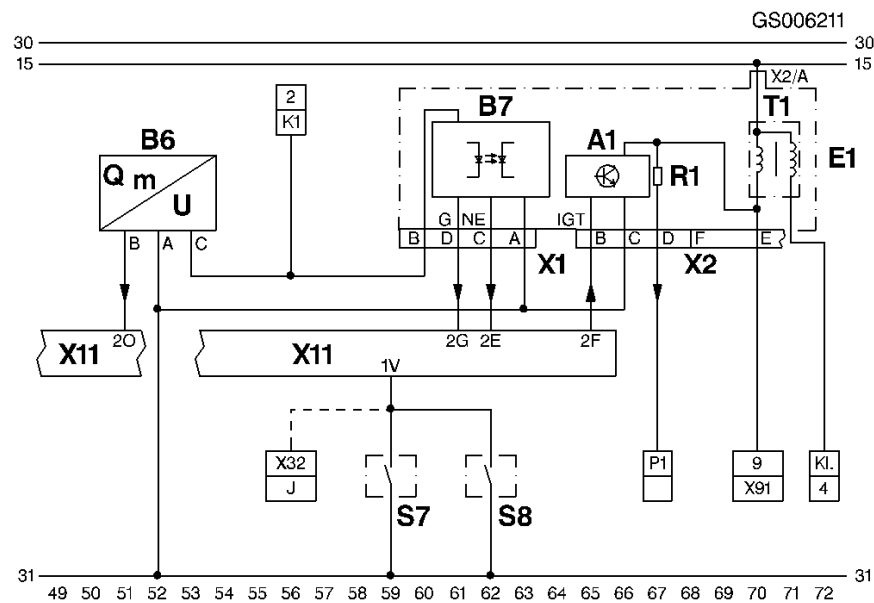

### ELECTRICAL TERMINAL DIAGRAM

A1 = Ignition driver stage  
B6 = Air-mass meter

S8 = Neutral switch  
T1 = Ignition coil

## Диагностика автомобилей SIS/CAS

MAZDA / 626 2.0i 16V Hatchback / 09/1991 - 05/1994 / Седан-накл.з.ч./б.накл.з.части  
(MAZ 346)

B7 = Engine-speed/ref.-mark sensor

E1 = Ignition distributor

G = Reference-mark signal

IGT = Ignition signal

Kl. = Terminal

K1 = Main relay

NE = Engine-speed signal

P1 = Rev counter

R1 = Resistor

S7 = Clutch switch

X1 = 4-pin connector at ignition  
distributor

X2 = 6-pin connector at ignition  
distributor

X11 = Engine control unit connector

X32 = Vehicle speed control control unit  
(if installed)

X91 = Diagnostic connector

30.08.2011

17:00:35